

CHAPTER 6 INSPECTION

6.1 HOLD-DOWN UNIT INSPECTION

Use Figure 6.1 A as a guide on how to find and remove obstructions under the hold-down unit.

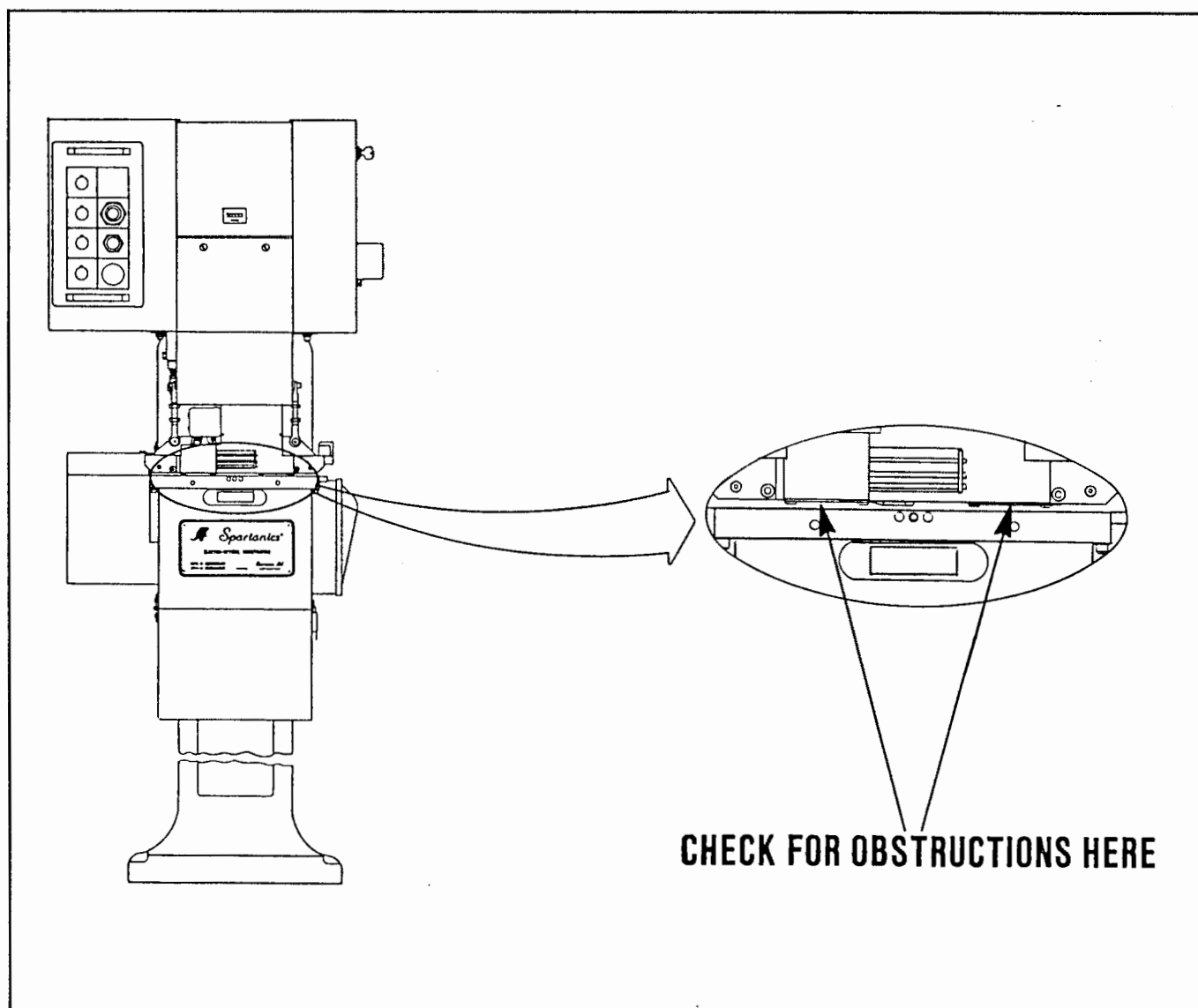

Figure 6.1 A

6.2 CORRECTOR PADS INSPECTION

Use the Figure 6.2 A as a guide on how to find and remove obstructions around the corrector pads.

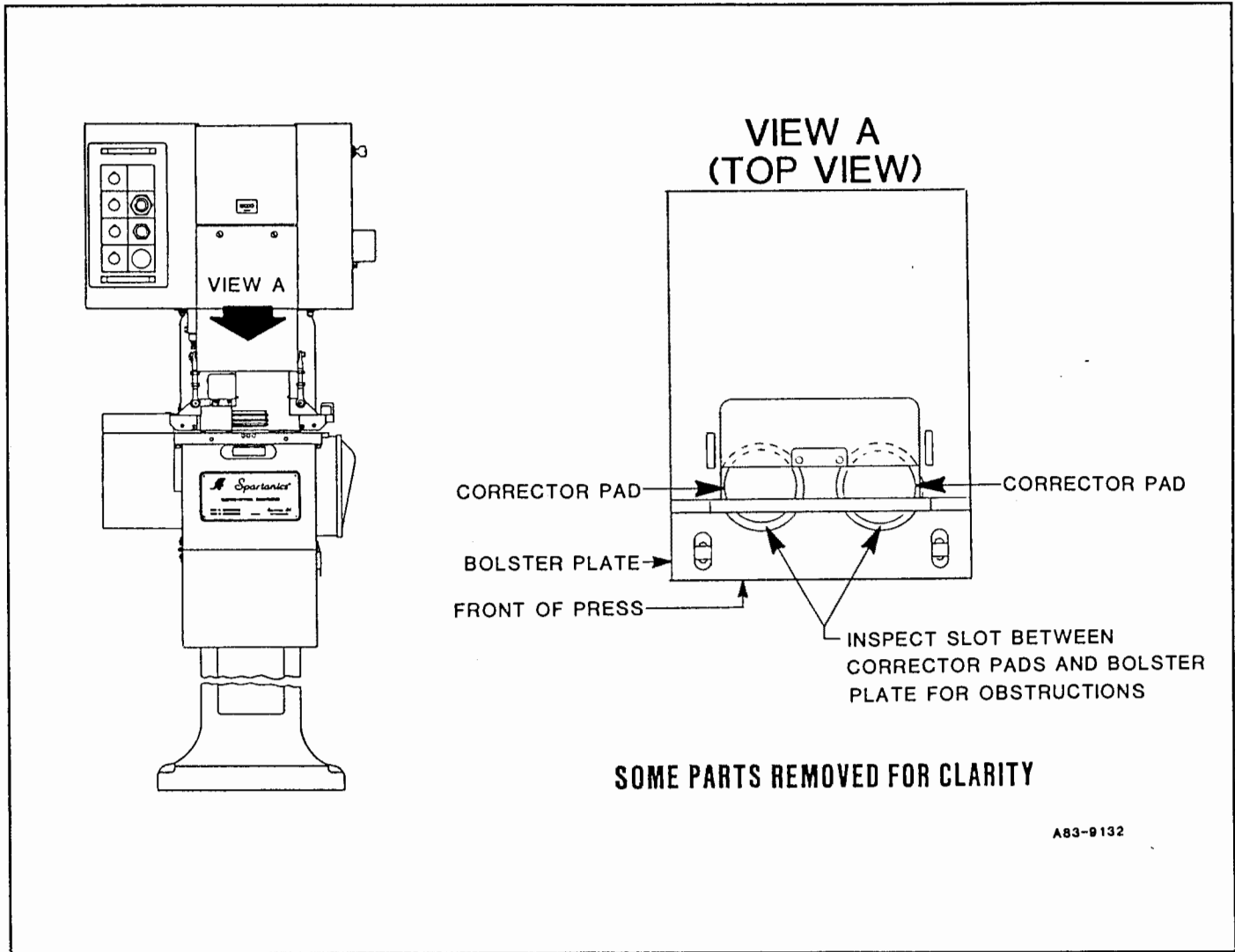

Figure 6.2 A